

1

2

3

4

5

6

7

8

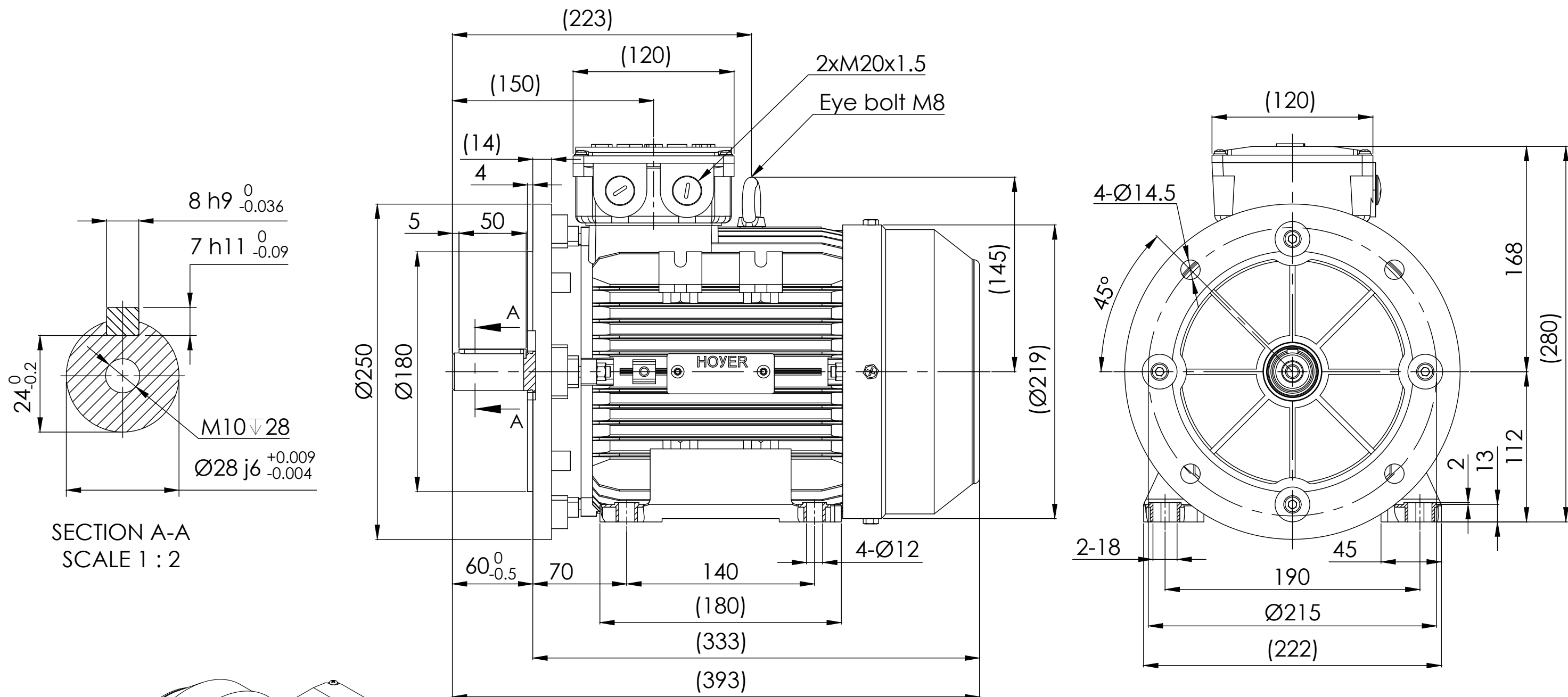

SECTION A-A  
SCALE 1 : 2

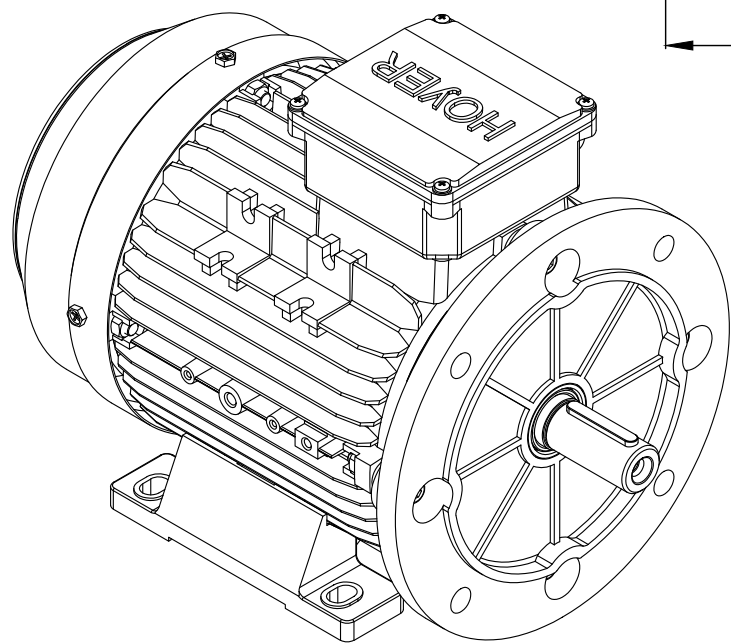

Note:

- All dimensions are in mm
- Tolerances not informed on the drawing according to the mounting tolerance table.

Mounting tolerance		<b>HOYER</b> EXCEEDING EXPECTATIONS		Hoyer Motors Over Hadstenvvej 42, DK-8370 Hadsten Tel : +45 86982111 Fax: +45 86981779 www.hoyermotors.com			DEBUR AND BREAK SHARP EDGES	DRAWING NOT IN SCALE	
Dimensions range	Tolerance	REV.	LOCATION	DESCRIPTION	DATE	RESP.	APPROVED	OUTLINE DRAWING	
0<D≤400	±10	0	N/A	First issued	25/10/2024	L&T	Hoyer	TITLE: HMA3-112M-2p-B35	
400<D≤1000	±20	1	N/A	Corrected spigot	05/01/2026	NKH	MOK	DWG NO.: TD-ID-D90183	
1000<D≤2000	±30							A3	
2000<D≤4000	±35							SCALE:1:10	
4000<D≤8000	±40							Weight: 34.1 kg	
Unit: mm								SHEET 1 OF 1	
Representation of the machine is illustrative only Some features may not be represented For installation or maintenance, consult operation manual				Protection: IEC 60034-5		Machined Part: ISO 2768		DWG NO.: TD-ID-D90183	
				Dimension: IEC 60072		Weld Constr: ISO 8015			
				Tolerance: ISO 286		Castings: ISO 8062			
				Key: IEC 60072					